

The background of the cover is a composite image. The upper portion shows a clear night sky with the Milky Way galaxy visible as a bright, hazy band of light. The lower portion shows a dark, rocky landscape with large, rounded boulders in the foreground, some of which are illuminated from the side, creating strong shadows and highlights. The overall color palette is dominated by the blues and greys of the night sky and the dark, earthy tones of the rocks.

# Earth & Space Sciences

**Laboratory Manual with Performance Assessments**

**Written within the Next Generation Science Standards Framework  
& Aligned to the New York Science Learning Standards**

Written by: Rosemarie Sanders





**SAMPLE COPY**  
of the  
**Earth & Space Sciences**  
**Laboratory Manual**  
**with Performance Assessments**

The Laboratory Manual is written within the NGLSS framework and aligns to the NY Science Learning Standards. It correlates with the 2024 NYS Earth & Space Sciences Reference Tables.

**The New Earth & Space Science Laboratory Manual:**

- 40 hands on Labs
- 8 Cluster based Performance Assessments
- 260 pages

**Each Lab contains:**

- Overview
- Investigative Statement
- Budget conscious lab
- 10 Clarifying Questions
- Claim
- Conclusion



**Proven to improve Regents scores.**

To preview additional units, please visit:  
[www.topicalrbc.com](http://www.topicalrbc.com) (follow Earth Science link)

ONLY \$10.00 each

For more information call 1-800-847-0854

# ABOUT THIS LABORATORY HANDBOOK

Welcome to Earth & Space Sciences. You are about to embark on an exciting course of study to help you understand the workings of your home planet. Earth Science is an applied science. That means you will learn about your home using many different science disciplines. There will be physical science, geography, chemistry, and physics.

There are forty investigations in this book related to and intrinsically linked to the Earth & Space Sciences. Each investigation is just that, a puzzle that must be solved with information from your knowledge of Earth Science.

Each investigation is followed by ten questions. Each question is more in depth than the previous one. All questions are to be answered in complete sentences. Single word answers do not fully explain your understanding of the material.

At the end of each unit is a *cluster based Performance Assessment* with 5 short answer and extended response questions.

## **Each lab contains the following:**

**Investigative Statement:** After reading the opening passage, one would make a single statement that sums up the passage and is the lens in which the investigation is solved. After the Investigative Statement, one needs to gather their thoughts and sketch a model of what one would do to verify the investigative statement. There are prompts to help with the sketch.

**Clarifying Questions:** The clarifying questions are based on the results of your investigation as well as the pre-lab readings. Some questions call on your knowledge of Earth & Space Sciences as well your ability to read the Earth & Space Sciences Reference Tables.

**Claim:** Make a statement about what you learned. It may be a response to your Investigative Statement, or a contradiction. However it is couched, you learned something so say what it is.

**Conclusion:** This fully explains your claim. This includes the understanding of the material, the processes that lead to the Claim.

The author:

**Rosemarie Sanders,**

Earth Science Teacher, Retired

Author, Earth Science Investigations

Biology: the Science of Life in Its Living Environment

Founder and First President New York Earth Science Teachers Association

Served as Subject Area Representative and Director at Large, Earth Science

Science Teachers Association of New York State

# Earth & Space Sciences

## Table of Contents

---

### **UNIT 1 : Finding Your Way**

1	Why is the Sky Blue?.....	1
2	Density of Liquids .....	7
3	Human Impact on the Environment.....	12
4	Latitude, Longitude and Time.....	17
5	Upon the Ocean .....	23
6	Where is the Sun? .....	28
	<i>PA1 : Follow the Drink Gourd</i> .....	32

### **UNIT 2 : Minerals and Rocks**

7	Mineral Identification .....	35
8	Mineral Resources .....	42
9	Igneous Rock Identification .....	47
10	Sedimentary Rock Identification .....	53
11	Metamorphic Rock Identification .....	59
12	Rock Cycle.....	65
	<i>PA2 : Eureka!</i> .....	70

### **UNIT 3 : Earth's Moving Surface**

13	Mercalli Scale .....	73
14	Earthquake Location.....	79
15	Volcano Location .....	85
16	Pangea.....	90
	<i>PA3 : Whats Shakin?</i> .....	96

### **UNIT 4 : Earth's Surface Processes**

17	Chemical Weathering.....	100
18	Physical Weathering.....	104
19	Rock Abrasion .....	108
20	Local Water .....	113
21	Stream Beds .....	116
22	Landscapes.....	125
23	A Tale of Two Lighthouses .....	130
	<i>PA4 : Hurricane Agnes</i> .....	139

# Earth & Space Sciences

## Table of Contents

---

### **UNIT 5 : The Rock Record**

24 Stratigraphy.....	143
25 Geologic Calender .....	149
26 Radioactivity.....	153
<i>PA5 : The Oxygen Revolution</i> .....	158

### **UNIT 6 : Atmosphere**

27 Air .....	161
28 Clouds .....	167
29 Cloud Height.....	173
30 Station Models .....	177
<i>PA6 : Blustery Day</i> .....	184

### **UNIT 7 : Climate**

31 Weather Map.....	187
32 Hurricanes.....	191
33 Seasons .....	197
34 Greenhouse Effect.....	203
<i>PA7 : Frost Fairs</i> .....	211

### **UNIT 8 : Space Science**

35 Lunar Orbit and Phases.....	215
36 Modeling Eclipses.....	219
37 Tides and Time.....	225
38 Starry Night .....	231
39 Orion.....	237
40 Kepler's Laws .....	245
<i>PA8 : A Comet's Journey</i> .....	255



# 1 Why is the Sky Blue?

**How To Use This Lab Book:** The investigation will be annotated. It will show how the lab is and what is expected of the Earth Science Student.

***Investigative Statement:** The following passage has information that will help you to perform an investigation. Read the following passage carefully and determine what specific aspect is to be solved. The Investigative Statement describes an aspect of the passage that you will focus on.*



Our closest star, the sun, emits most of its light in what is called the visible spectrum, or all the colors of the rainbow. Most organisms that live on the land or near the surface of the water, can interpret the light based on the visible spectrum. The light, in its various wavelengths, energizes different areas of our eyes. Some animals, such as bumble bees, can see ultraviolet. This helps bees find the part of the flower that the bee is looking for. Snakes such as pit vipers can see infrared light. This is a light that is associated with the heat seeking predators. The heat seeking sidewinder missile is named after the pit-viper. Both of these wavelengths of light are not visible to humans. What differentiates the different segments of the electromagnetic spectrum are the wavelength.

One of the earliest scientific questions children ask is, “Why is the sky blue?” Some people have an answer that at first seems logical, but after giving it some thought, it doesn’t make sense.

Light can behave in different ways. Light can reflect, refract, or scatter. Reflection is light bouncing off a surface because that light was not absorbed. The best example of reflection is the light reflected off a mirror. Refraction is how light behaves when the colors of white light are separated. The best example of refraction is when a rainbow is formed from water droplets in the sky.

The Visible Light Spectrum is in your lab folder. The set of clarifying questions will be referencing this page for answers. The visible light spectrum includes the color, hue, and wavelength of each of the segments we call light.

The sun’s light reaches our planet at a range that is greatest in the range of  $4.0 \times 10^{-5}$  and  $7.0 \times 10^{-5}$ . The sun intensity peaks at  $4.5 \times 10^{-5}$  and  $4.9 \times 10^{-5}$ . This light can reflect, refract, or scatter.

Scattering is more complex. Each particle that light hits scatters the light in all directions. Each molecule in the atmosphere scatters completely in all directions when light strikes it. Rayleigh (rah-LAY) scattering occurs when the light is separated and scattered in all directions for each molecule. The shorter the wavelength, the more the intense the scattering. Other wavelengths do not scatter as readily. The intensity of the scatter is related to the short atmospheric distance. The more that light travels through the atmosphere, the longer wavelengths are expressed.



**Vocabulary:**

**Rayleigh Scattering:** A form of scatter where only the shortest wavelengths of white light are uniformly scattered in all directions. This occurs when light strikes an object smaller in size to the wavelength.

**Reflection:** When light is not absorbed, it bounces off whatever the light struck.

**Refraction:** When white light is separated into its individual wavelengths.

*Science, Technology, and Engineering Practices: In the following space, you will be “Asking Questions” based on the passage that you read. You will find a segment of the phenomenon that is intriguing and you will want to investigate it. The statement regarding what you are investigating will be written in the area “Phenomenon.”*

*Follow the prompts written in the space, as they will be different in other investigations. For purposes of this investigation, it is using the Science, Technology and Engineering Practice, “Asking Questions.” See the prompts along the bottom of the sketch box that describe what is to fill the box. In the model that is sketched, Ask a Question, determine its Testability, include Labels, and predict outcomes.*

**Asking Questions**

**Investigative Statement:** \_\_\_\_\_  
\_\_\_\_\_

**In the space provided:** ask a question – sketch a model – label model – identify variables

**Activity:** In the following section you will be asked to perform tasks that will assist you in clarifying your Phenomenon. Follow the tasks and describe that which you have learned.

1. Review the Visible Light Spectrum on the back cover of the book to fill in the chart below.
2. The wavelength of ultraviolet light range is  $0.1 \times 10^{-5}$  to  $4.0 \times 10^{-5}$ . You will see that has been filled in already.
3. Complete the rest of the chart using the Visible Light Spectrum.

**Chart:** Notice that the range, listed above includes the notation  $10^{-5}$ . It is not necessary to include it in the space provided.

**Visible Light Spectrum Wavelength x  $10^{-5}$**

Color	Ultraviolet	Violet	Blue	Green	Yellow	Orange	Red
Wavelength	0.1 - 4.0						

These are clarifying questions to serve as a guide for understanding the observations. Answers must be in complete sentences and should mirror the question in each answer.

**Clarifying Questions:**

1. Look at the Visible Light Spectrum on the back cover. What is the wavelength range of visible light?

---

---

---

2. What color is the shortest wavelength range of visible light?

---

---

---

## Solar Output in the Atmosphere

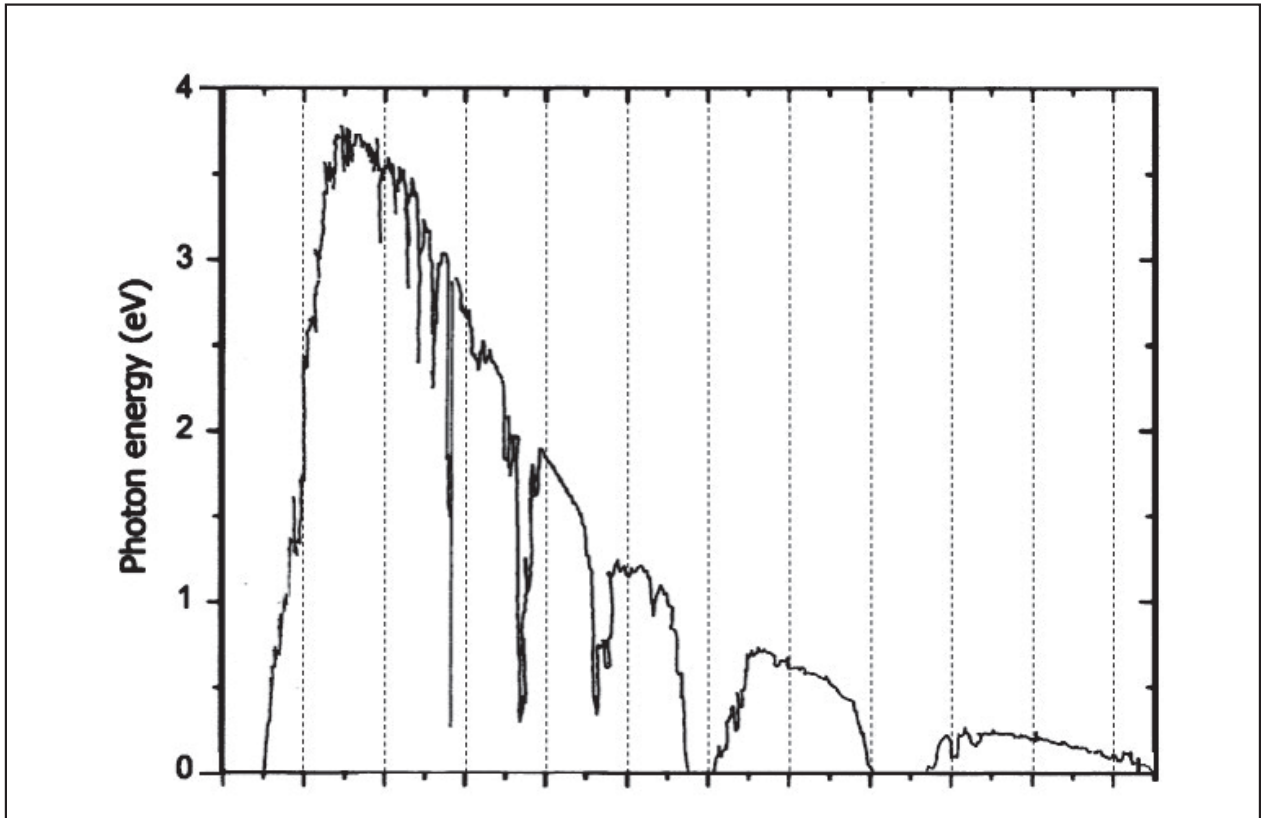

3. Look at the graph above. Referencing your Visible Spectrum Chart on the back cover, what is the wavelength range that is the peak solar output of energy striking the atmosphere?

---

---

4. What is the color that is the sun's greatest output?

---

---

5. Infer: Which has a greater outcome quantity or quality?

---

---

6. Look at the Solar Output in the Atmosphere chart. There is a sudden peak and a sudden drop of solar output dropping to less than 0.5 photon energy. Note that range and record it below.

---

---

7. Refer to the Visible Spectrum chart. Express a correlation, if any.

---

---

---

---

8. Longer wavelengths pass through increased atmosphere. Which is the longest wavelength of the visible spectrum?

---

---

9. The sun appears to travel across the sky throughout the day. The amount of atmosphere that the sun's light passes through is the lowest at solar noon and greatest at sunset. Why are sunsets red?

---

---

---

10. Why is the sky blue?

---

---

---

---



**Cross Cutting Concepts:** Now that you have completed much of this investigation, you will make a statement regarding what you have learned. Your statement will be a simple Claim, a one sentence declarative statement. In the space provided, you will be describing the functions, of light energy. The behavior of light when it interacts with material in the atmosphere. Determine how the functions work to produce an effect. You will be describing these functions and sketch a model of your findings. Variables and their relationship should be included in the Cross Cutting Concept.

**Claim:** \_\_\_\_\_

**The way an object is shaped or structured determines many of its properties and functions.**

**(What have you learned)**

**Conclusion:** Fully explain your conclusion in terms of structure and function, in citing evidence from your investigation.

**(How you learned it)**

---

---

---

---

---

---

---

---

---

---

# 9 Igneous Rock Identification

Igneous rocks are rocks that form when lava or magma cools. Lava and magma are both molten minerals. Lava is magma that has come out of the volcano.

The subtlety of where a rock forms determines what type of rock it will become. This is called origin of formation.

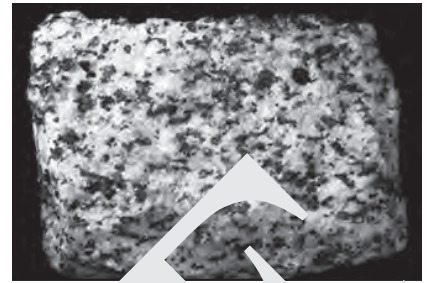

Rock that is formed when lava cools is called extrusive or volcanic. Lava on the exterior of the volcano is exposed to the air or water (underwater volcanoes) and cools quickly. These rocks sometimes don't even have time to form crystals; this is called glassy. Sometimes, gas gets trapped in the rock, giving the rock an appearance of being spongy. Rock that is formed when magma cools is called intrusive or plutonic.

Magma is in the interior of the volcano. The rock surrounding the volcano is an excellent insulator, making the magma cool very slowly. The mineral crystals can grow very large.

Geologists also classify igneous rocks based the minerals in the rock. As you study the Mineral Composition of Igneous Rock Identification chart, on the following page, you will infer that light colored and less dense rocks are called felsic, while denser, darker colored rocks are called mafic. Ultramafic rocks have only a few minerals. If a rock has only one mineral, it is called monomineralic.

Since the internal arrangement of atoms is the critical factor in determining the properties of minerals, how the magma cools determine what type of mineral forms.

## Planning and Carrying Out Investigations

**Investigative Statement:** \_\_\_\_\_

**In the space provided:** *sketch a plan – label – planning – data collection – variables – evaluate investigation*

**Materials:** • Igneous rocks kit • Magnifying lens • Metric ruler

**Procedure:**

Use the Scheme for Igneous Rock Identification and Mineral Composition of Igneous Rock chart below, the Model of Bowen's Reaction Series on the following page, magnifying lens, and metric ruler to identify the rocks and map out your findings using the dichotomous key.

**Scheme for Igneous Rock Identification**

ENVIRONMENT OF FORMATION		CRYSTALLINITY		TEXTURE	
IGNEOUS ROCKS	EXTRUSIVE (Volcanic)	Obsidian (usually appears black)		Basaltic glass	
		Pumice		Scoria	
		Vesicular rhyolite	Vesicular andesite	Vesicular basalt	
	INTRUSIVE (Plutonic)	Rhyolite	Andesite	Basalt	
Granite		Diorite	Diabase	Peridotite	
Pegmatite			Gabbro		
			non-crystalline		Non-vesicular
			less than 1 mm	Fine	Vesicular (gas pockets)
			10 mm or larger	Coarse	Non-vesicular
				Very coarse	

**CHARACTERISTICS**

LIGHTER ← → DARKER

LOWER → → HIGHER

Composition	Felsic	Intermediate	Mafic	Ultramafic
Rock types	Granite/Rhyolite	Diorite/Andesite	Gabbro/Basalt	Peridotite/Komatiite

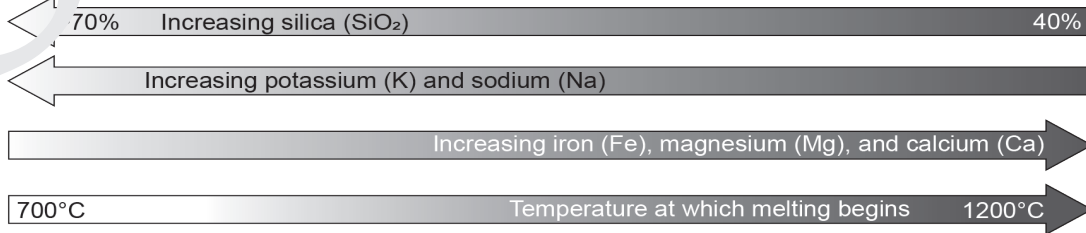
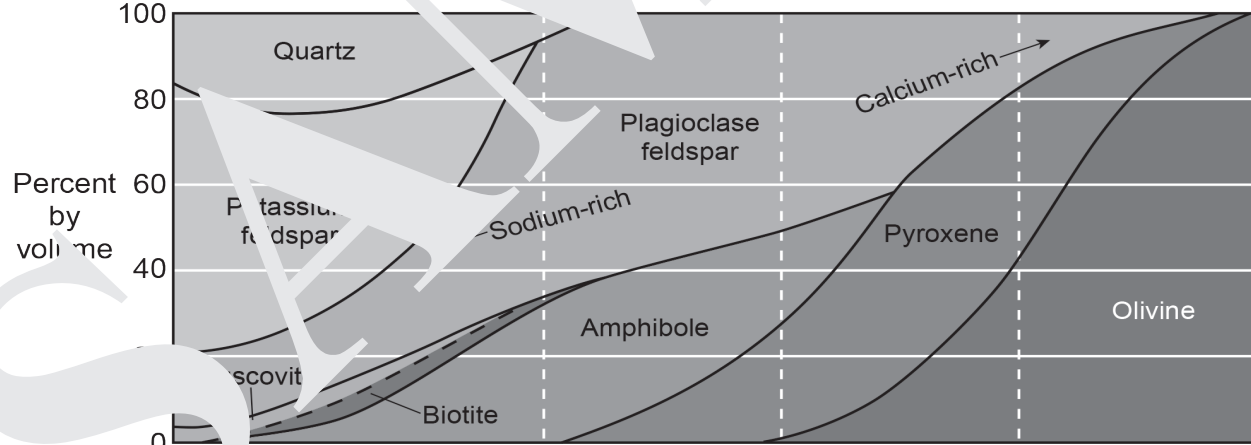

## Model of Bowen's Reaction Series

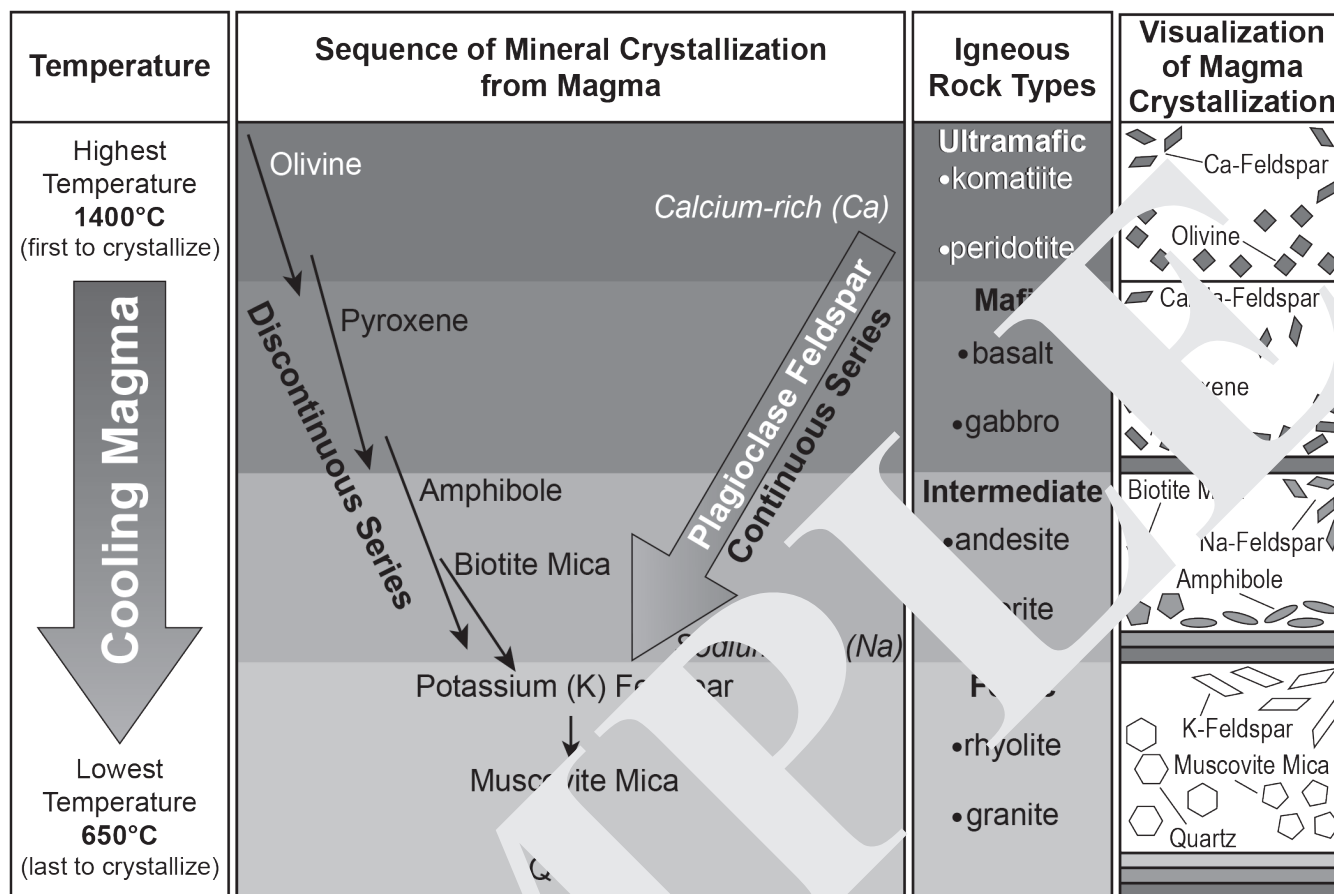

### Rock # 1

1. What is the crystal texture? (circle one) Glassy – Vesicular – Non-Vesicular
2. The grain size is: non-crystalline / < 1mm / 1mm – 10mm / 10mm or larger
3. Looking at questions 1 and 2 the rock is (extrusive / intrusive).
4. The rock is (light colored pink to light grey / dark colored dark grey to green).
5. Looking at question number 4, the rock is (felsic / mafic).
6. Looking at question 2, 3 & 5, the rock is \_\_\_\_\_.

### Rock # 2

1. What is the crystal texture? (circle one) Glassy – Vesicular – Non-Vesicular
2. The grain size is: non-crystalline / < 1mm / 1mm – 10mm / 10mm or larger
3. Looking at questions 1 and 2 the rock is (extrusive / intrusive).
4. The rock is (light colored pink to light grey / dark colored dark grey to green).
5. Looking at question number 4, the rock is (felsic / mafic).
6. Looking at question 2, 3 & 5, the rock is \_\_\_\_\_.



**Rock # 3**

1. What is the crystal texture? (circle one) Glassy – Vesicular – Non-Vesicular
2. The grain size is: non-crystalline / < 1mm / 1mm – 10mm / 10mm or larger
3. Looking at questions 1 and 2 the rock is (extrusive / intrusive).
4. The rock is (light colored pink to light grey / dark colored dark grey to green).
5. Looking at question number 4, the rock is (felsic / mafic).
6. Looking at question 2, 3 & 5, the rock is \_\_\_\_\_.

**Rock # 4**

1. What is the crystal texture? (circle one) Glassy – Vesicular – Non-Vesicular
2. The grain size is: non-crystalline / < 1mm / 1mm – 10mm / 10mm or larger
3. Looking at questions 1 and 2 the rock is (extrusive / intrusive).
4. The rock is (light colored pink to light grey / dark colored dark grey to green).
5. Looking at question number 4, the rock is (felsic / mafic).
6. Looking at question 2, 3 & 5, the rock is \_\_\_\_\_.

**Rock # 5**

1. What is the crystal texture? (circle one) Glassy – Vesicular – Non-Vesicular
2. The grain size is: non-crystalline / < 1mm / 1mm – 10mm / 10mm or larger
3. Looking at questions 1 and 2 the rock is (extrusive / intrusive).
4. The rock is (light colored pink to light grey / dark colored dark grey to green).
5. Looking at question number 4, the rock is (felsic / mafic).
6. Looking at question 2, 3 & 5, the rock is \_\_\_\_\_.

**Clarifying Questions:**

1. What is the melting / solidification temperature of olivine?

\_\_\_\_\_

2. What mineral has the lowest melting / solidification temperature?

\_\_\_\_\_

3. What does vesicular mean?

\_\_\_\_\_

\_\_\_\_\_





# 21 Stream Beds

---

Running water is a major agent of erosion. The stream bed is affected by its shape and the angle in which it flows. The stream flow then carves out the stream channel. The water in the stream travels at a speed dependent on the angle of the slope. The channel in which the stream travels is affected by the slope. Young streams tend to be straight and have steep slopes. As streams mature in their landscapes, the stream will begin to meander. Fully mature streams have flood plains in areas the stream bed gets pinched and forms oxbow lakes.

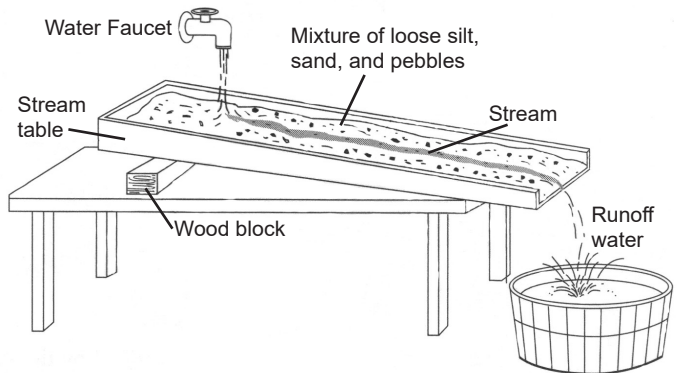

## Analyzing and Interpreting Data

Investigative Statement: \_\_\_\_\_

---

In the space provided: *organize data - relationships in data sets - variables - interpret data*



- Materials:**
- Stream table with adjustable height
  - Water
  - Mixture of gravel and sand

**Procedure 1 - Slight Angle - Straight Channel:**

1. Set up the stream table so that it is at a *slight* angle.
2. Add the gravel and sand mixture in the middle of the stream table. Smooth out the sediments, producing a slightly sloping landscape. Do *not* put any sediments in the lower end of the stream table.
3. Add water to create a “lake” at the upper end of the stream table. Add water to the lower end to produce a “quite body of water”.
4. Make a shallow *straight* channel through the sediment mixture.
5. Slowly add water into the lake area so that it flows through the channel to the “quite body of water”.
6. Continue adding water for 5 minutes while recording observations.

**Observations:**

---

---

---

---

**Draw the final results of your stream table in the box below.**



**Procedure 4 - Evaporation:**

Your teacher will select one of the stream tables to observe the results after evaporation.

**Observations:**

---

---

---

---

---

---

---

**Draw the final results of your stream table in the box below.**



### Clarifying Questions:

1. Which stream had the greatest water velocity?

---

---

2. Which stream had the deepest channel?

---

---

3. What happened to the sides of the channel as far as erosion and deposition?

---

---

4. What are some ways in which the stream channel could be adjusted?

---

---

**Directions:** Use the Relationship of Transported Particle Size to Water Velocity chart for questions 5–8.

**Relationship of Transported Particle Size to Water Velocity**

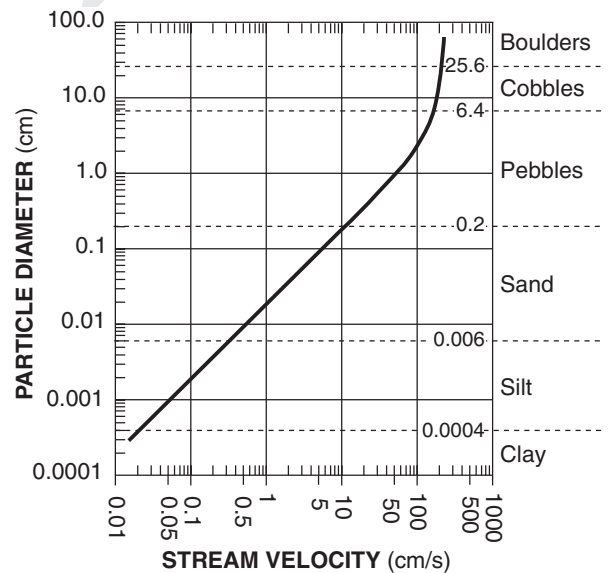

5. What is the minimum stream velocity of water needed to transport the coarse sand?

---

6. If you had your stream traveling at a velocity of 100 cm per second, what is the largest particle that could be transported?

---

This generalized graph shows the water velocity needed to maintain, but not start, movement. Variations occur due to differences in particle density and shape.

7. As water slows to still water, what happens to the sediment that was being transported?

---



---

8. The illustration below depicts the method in which materials deposit in horizontal sorting.

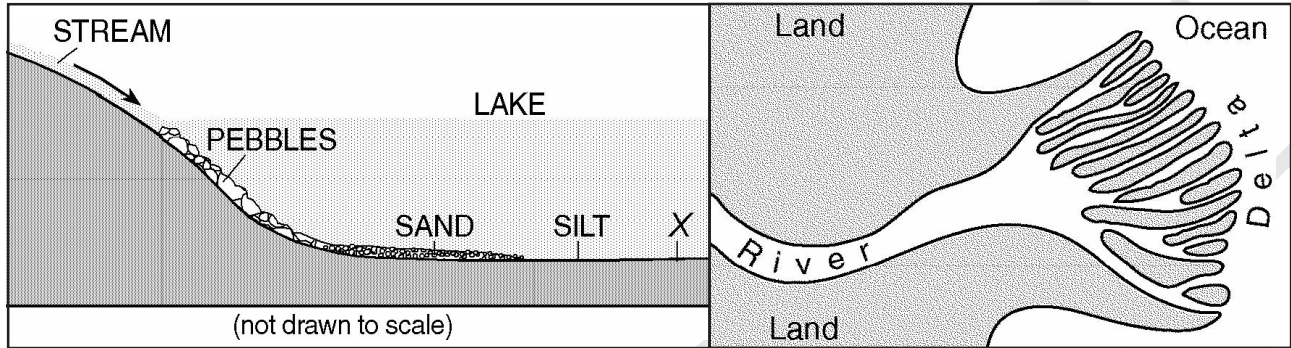

Explain the processes illustrated in the chart above and the formation of the delta using the Relationship of Transported Particle Size to Water Velocity chart on the previous page.

---



---



---



---

9. In the following stream pattern, please determine the stream bed from A to A'.

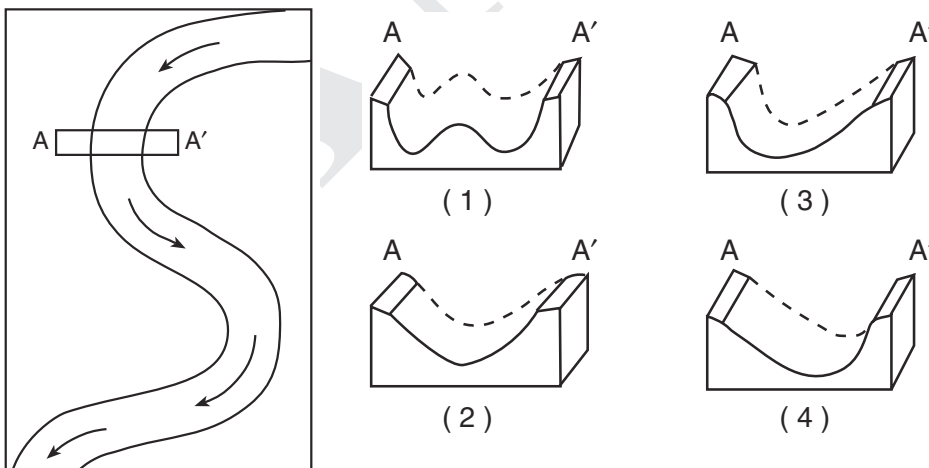

9 \_\_\_\_\_



10. Shown below are three stages of stream development. Think of the three different types of stream channels that you created, compare your streams to the three types below.

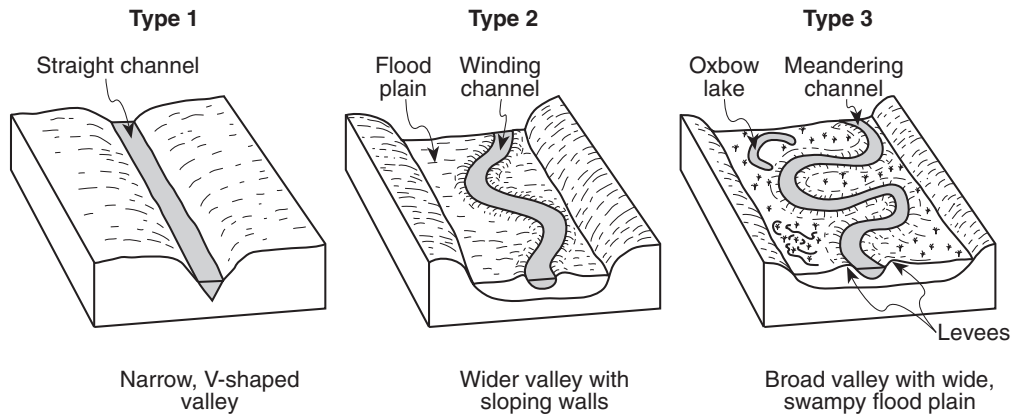

---

---

---

---

---

---

---

---

**Claim:** \_\_\_\_\_

---

**Modern civilization depends on major technological systems, and new technologies can have deep impacts on society and the environment, including some that were not anticipated.**

**Conclusion:** Analysis of costs and benefits is a critical aspect of decisions about technology.

---

---

---

---

---

---

---

---

# 38 Starry Night

---

One of Vincent Van Gogh's most famous paintings is Starry Night. It is a beautiful and evocative painting. It is considered to be one of the most recognizable pieces of art. It depicts the many colors of the night sky. It captures a sleepy little French town under a wildly bright starscape. The stars are featured in differing colors and brightness. It is in these colors that stars characteristics can be interpreted and inferred.



Stars have captured the imagination of humanity since before recorded history. There are countless stars in the sky. After people began to illuminate the night, the ability to see stars have greatly diminished. It was only there very brightest that people saw patterns in the night sky and interpreted them as images of mythology in what we call constellations.

Scientists who study stars are astronomers. Astronomers also look at the night sky in awe and study the clues that stars give to us behind the twinkling in the night sky. Astronomers study the light that stars emit. Starting with the closest and most familiar, we study the Sun. All stars are compared to the Sun in size, brightness, color, and temperature.

## Obtaining and Communicate Information

**Investigative Statement:** \_\_\_\_\_

**In the space provided:** thinking of information, obtain – sketch – evaluate – communicate – plan

### Life Cycles of Stars Model

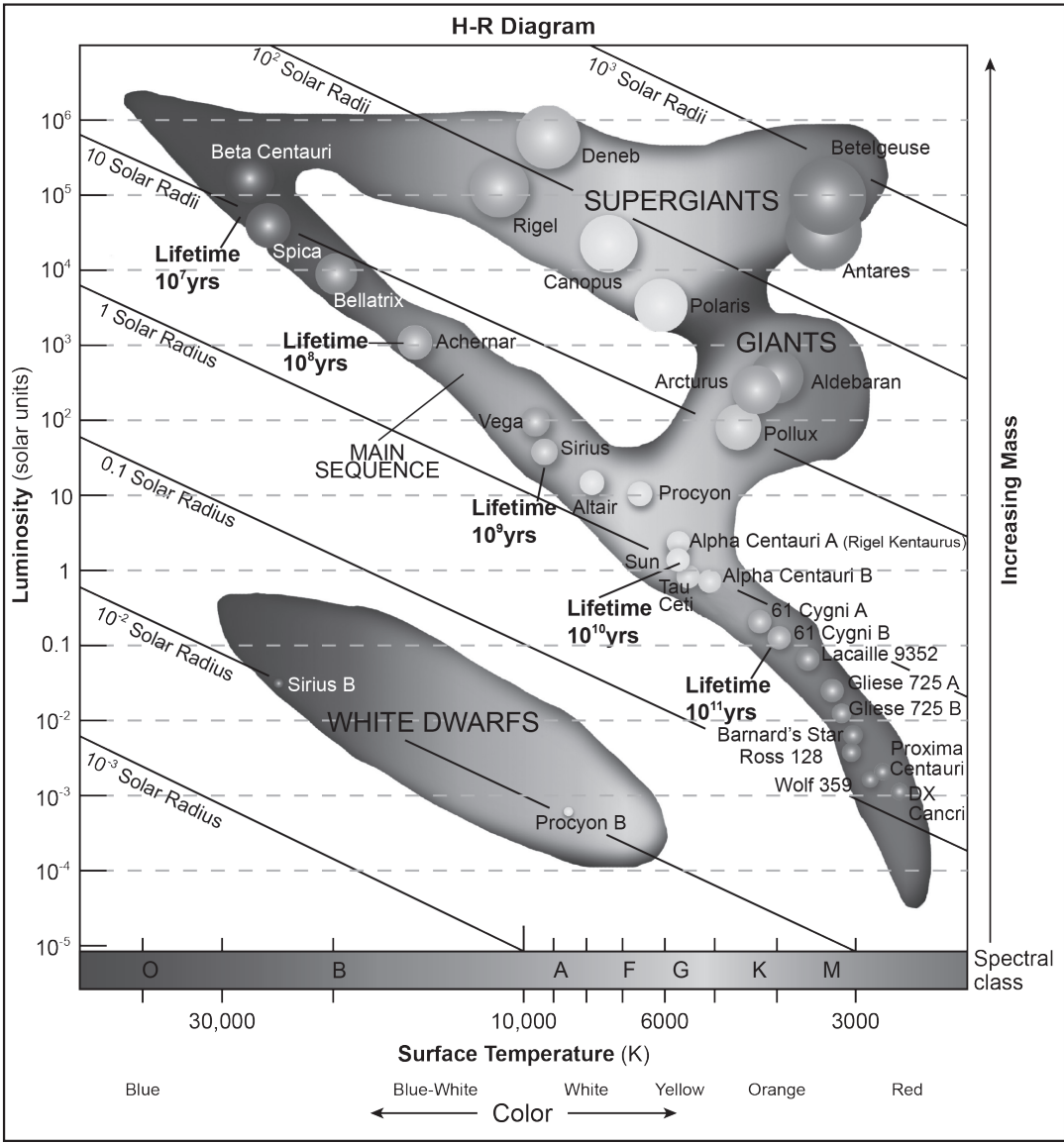
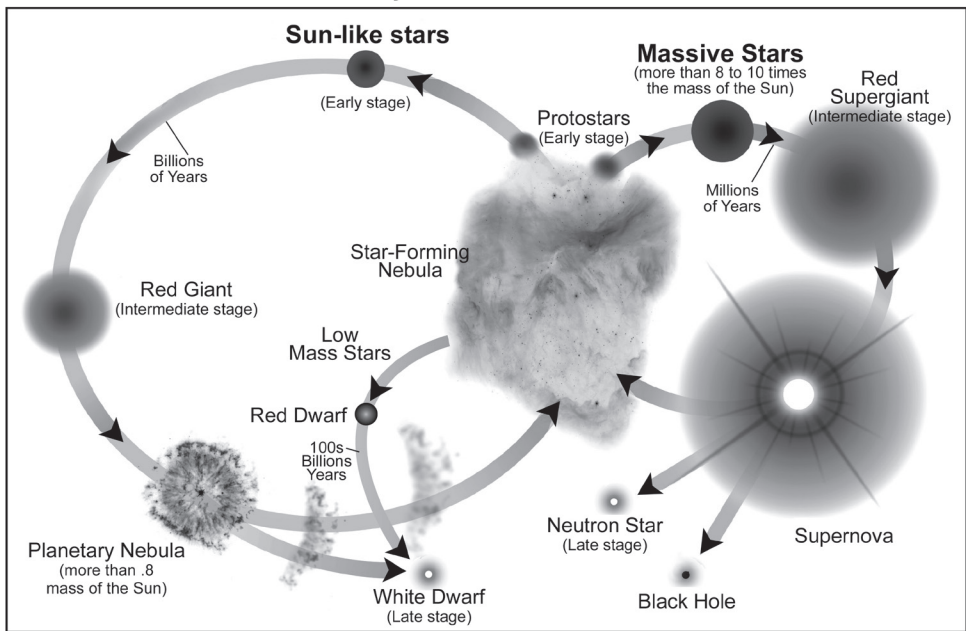

**Directions:** In the following exercise, we will classify sun-like stars in using the Life Cycles of Stars Model and the H-R Diagram on the previous page.

### Sun-like Stars

#### **Early Stage**

Star: \_\_\_\_\_

Classification: \_\_\_\_\_ Color: \_\_\_\_\_

Temperature: \_\_\_\_\_ K Spectral Class: \_\_\_\_\_

Size: \_\_\_\_\_ x the solar radius Luminosity: \_\_\_\_\_ solar units

Approximate lifespan of selected star: \_\_\_\_\_ years

#### **Intermediate Stage**

Star: \_\_\_\_\_

Classification: \_\_\_\_\_ Color: \_\_\_\_\_

Temperature: \_\_\_\_\_ K Spectral Class: \_\_\_\_\_

Size: \_\_\_\_\_ x the solar radius Luminosity: \_\_\_\_\_ solar units

Approximate lifespan of selected star: \_\_\_\_\_ years

#### **Late Stage**

Star: \_\_\_\_\_

Classification: \_\_\_\_\_ Color: \_\_\_\_\_

Temperature: \_\_\_\_\_ K Spectral Class: \_\_\_\_\_

Size: \_\_\_\_\_ x the solar radius Luminosity: \_\_\_\_\_ solar units

Approximate lifespan of selected star: \_\_\_\_\_ years

#### **Low Mass Stars (0.8 the mass of the sun)**

Star: \_\_\_\_\_

Classification: \_\_\_\_\_ Color: \_\_\_\_\_

Temperature: \_\_\_\_\_ K Spectral Class: \_\_\_\_\_

Size: \_\_\_\_\_ x the solar radius Luminosity: \_\_\_\_\_ solar units

Approximate lifespan of selected star: \_\_\_\_\_ years

## Massive Stars

### Early Stage

Star: \_\_\_\_\_

Classification: \_\_\_\_\_ Color: \_\_\_\_\_

Temperature: \_\_\_\_\_ K Spectral Class: \_\_\_\_\_

Size: \_\_\_\_\_ x the solar radius Luminosity: \_\_\_\_\_ solar units

Approximate lifespan of selected star: \_\_\_\_\_ years

### Intermediate Stage

Star: \_\_\_\_\_

Classification: \_\_\_\_\_ Color: \_\_\_\_\_

Temperature: \_\_\_\_\_ K Spectral Class: \_\_\_\_\_

Size: \_\_\_\_\_ x the solar radius Luminosity: \_\_\_\_\_ solar units

Approximate lifespan of selected star: \_\_\_\_\_ years

### Clarifying Questions:

1. Why is it that we cannot see the night sky as seen when Starry Night was painted?

\_\_\_\_\_  
\_\_\_\_\_

2. What is the color of Beta-Centauri?

\_\_\_\_\_  
\_\_\_\_\_

3. Bellatrix and Sirius, although different colors, are both classified as what kind of stars?

\_\_\_\_\_  
\_\_\_\_\_

4. Describe the limiting factor when determining the early-stage sun-like star.

\_\_\_\_\_  
\_\_\_\_\_



5. According to the H-R Diagram, what is the size of Pollux, relative to the sun?

---

---

6. Describe the brightest star by name and luminosity in terms of solar units.

---

---

7. Describe the most massive star by name and luminosity in terms of solar units.

---

---

8. What is the expected lifetime of Spica?

---

---

9. What is the expected lifespan of 61 Cygni A?

---

---

10. Plot the relationship between life span and relative age of stars in the main sequence.

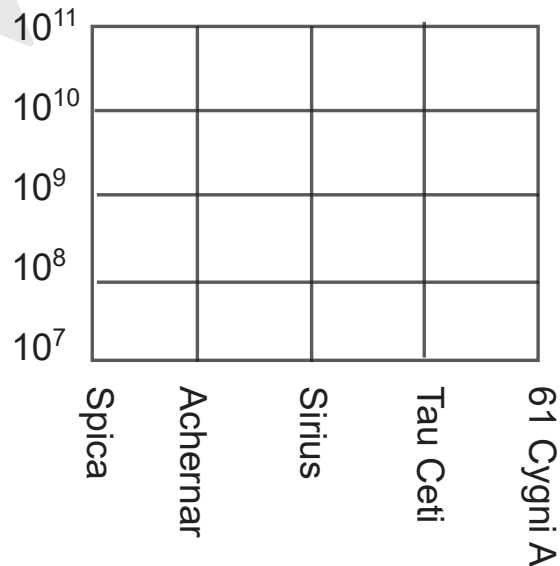



# **A Comet's Journey**

***Read the following the passage and determine the conditions of the solar system in which this comet travels.***

## ***Phenomenon***

Comets are objects in our solar system that orbit the sun. Comets do have regular paths, yet very different from the orbits of planets, planetoids, and asteroids. Comets orbit the sun in long ellipses.

Comets are made up of rock, ice, and frozen gases. Comets have three parts. The core, or nucleus, of a comet is made up of rock and ice. The core is surrounded by a cloud of gas and dust. This cloud is the coma. The nucleus and coma form the head of the comet. The tail forms as the comet comes near the sun. The tail is made up of glowing gas and dust streaming out from the head. A comet's tail always points away from the sun.

Comets are believed to originate in the Oort Cloud and the Kuiper Belt. The Kuiper Belt, is a region of the solar system where material is believed to be remnants from the solar system's early formation. The Kuiper Belt is past the orbit of Neptune. The Oort Cloud lies far beyond Pluto and the most distant edges of the Kuiper Belt. It is believed to be a giant spherical shell surrounding the Sun, planets and Kuiper Belt Objects.

Hailey's Comet is a regular comet passing by Earth approximately every 76 years. It is so well documented, that it could be found in ancient texts. While comets were believed to make only one pass through the solar system, English astronomer Edmund Hailey predicted the appearance of the comet using gravitation and planetary motion theories from Sir Isaac Newton.

The understanding is that the trajectory of Hailey's comet is approximately 17.35 AU in the semi-minor axis while its semi-major axis is approximately 17.93 AU. These numbers were derived by observations of the comet. Notice it is a semi-axis, which means half.

The comet is predicted to return to our view on May 7, 2134. It is an object roughly 11 km across. It travels at a rate of speed of 65 km per second. It travels close to Earth on its path to the sun, but takes a wider sweep on its journey through the solar system.

**Stimulus**

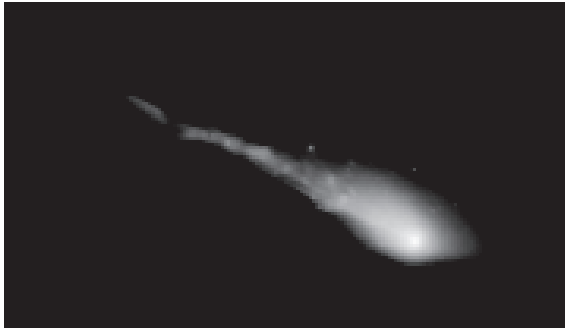
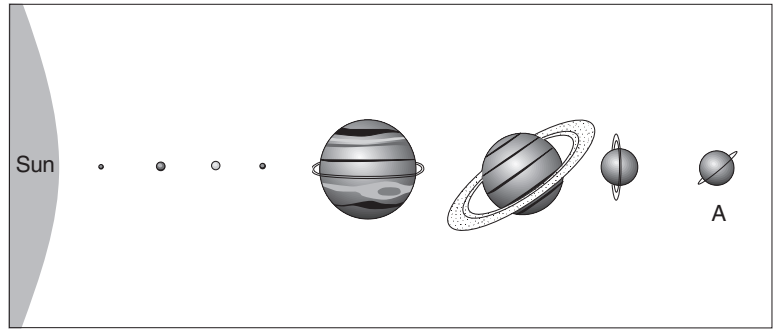

Photo by Dan Bartlett



**Prompt** — Answer the following questions.

1. Convert minor axis to km, and convert major axis to km. (Show work)

2. During the Great Bombardment, 4 billion years ago, it is believed that comets crashed into our planet. Knowing a comet's composition, explain the outcome of this.

---

---

---

---

---

---

---

---

---

---

3. Determine the eccentricity of Halley's Comet.

$$\text{Eccentricity} = \frac{\text{semi minor axis}}{\text{semi major axis}}$$

4. Determine whether Halley's comet is a Kuiper Belt Object or from the Cloud or Oort. Explain and defend your conclusion.

---

---

---

---

---

---

5. In 2014, NASA (National Aeronautic and Space Administration) and ESA (European Space Agency) landed on Comet 67P/ Churyumov-Gerasimenko. What data would do you think these agencies were looking for?

---

---

---

---

---

---

---

---

---

---